

**TS8GSSD25S-S**  
**TS16GSSD25S-S/M**  
**TS32GSSD25S-S/M**  
**TS64GSSD25S-S/M**  
**TS128GSSD25S-M**  
**TS192GSSD25S-M**



## Description

Due to smaller size (fit the standard dimensions of 2.5" SATA Hard Disk Drives), huge capacity, high speed, and low power consumption, Solid State Disk is perfect replacement storage device for PCs, Laptops, gaming systems, and handheld devices.

## Placement



## Features

- RoHS compliant
- Fully compatible with devices and OS that support the SATA II 3.0Gbps standard
- Non-volatile Flash Memory for outstanding data retention
- Built-in ECC (Error Correction Code) functionality and wear-leveling algorithm ensures highly reliable of data transfer
- Shock resistance

## Dimensions

Side	Millimeters	Inches
A	100.00 ± 0.40	3.937 ± 0.016
B	69.85 ± 0.20	2.750 ± 0.008
C	9.50 ± 0.15	0.374 ± 0.004

**TS8GSSD25S-S**  
**TS16GSSD25S-S/M**  
**TS32GSSD25S-S/M**  
**TS64GSSD25S-S/M**  
**TS128GSSD25S-M**  
**TS192GSSD25S-M**



## Specifications

Physical Specification		
Form Factor	2.5-inch HDD	
Storage Capacities	8 GB to 192 GB	
Dimensions (mm)	Length	100.0 0 ± 0.40
	Width	69.85 ± 0.20
	Height	9.50 ± 0.15
Input Voltage	5V ± 5%	
Weight	55g ± 5g	
Connector	SATA 7+15 pins combo connector	

Environmental Specifications	
Operating Temperature	0 °C to 70 °C
Storage Temperature	- 40 °C to 85 °C

Power Requirements			
Input Voltage		5V ± 5% @25°C	
Mode		Max. (mA)	Max. (W)
Power Consumption (8/16/32/64GB)	Write <sub>(peak)</sub>	476.1	2.4
	Read <sub>(peak)</sub>	426.2	2.1
	Idle <sub>(peak)</sub>	144.0	0.7
Power Consumption (128GB)	Write <sub>(peak)</sub>	541.6	2.7
	Read <sub>(peak)</sub>	461.2	2.3
	Idle <sub>(peak)</sub>	142.1	0.7
Power Consumption (192GB)	Write <sub>(peak)</sub>	573.3	2.9
	Read <sub>(peak)</sub>	483.1	2.4
	Idle <sub>(peak)</sub>	146.2	0.7

**TS8GSSD25S-S**  
**TS16GSSD25S-S/M**  
**TS32GSSD25S-S/M**  
**TS64GSSD25S-S/M**  
**TS128GSSD25S-M**  
**TS192GSSD25S-M**



Performance		
Model P/N	Sequential Read <sub>(Max.)</sub>	Sequential Write <sub>(Max.)</sub>
TS8GSSD25S-S	150 MB/s	90 MB/s
TS16GSSD25S-M	150 MB/s	50 MB/s
TS16GSSD25S-S	150 MB/s	100 MB/s
TS32GSSD25S-M	150 MB/s	90 MB/s
TS32GSSD25S-S	150 MB/s	120 MB/s
TS64GSSD25S-M	150 MB/s	90 MB/s
TS64GSSD25S-S	170 MB/s	140 MB/s
TS128GSSD25S-M	150 MB/s	90 MB/s
TS192GSSD25S-M	150 MB/s	90 MB/s

Actual Capacity				
Model P/N	User Max. LBA	Cylinder	Head	Sector
TS8GSSD25S-S	15,621,984	15,498	16	63
TS16GSSD25S-M	31,277,056	16,383	16	63
TS16GSSD25S-S	31,277,056	16,383	16	63
TS32GSSD25S-M	62,586,880	16,383	16	63
TS32GSSD25S-S	62,586,880	16,383	16	63
TS64GSSD25S-M	125,206,528	16,383	16	63
TS64GSSD25S-S	125,206,528	16,383	16	63
TS128GSSD25S-M	250,445,824	16,383	16	63
TS192GSSD25S-M	375,685,120	16,383	16	63

**TS8GSSD25S-S**  
**TS16GSSD25S-S/M**  
**TS32GSSD25S-S/M**  
**TS64GSSD25S-S/M**  
**TS128GSSD25S-M**  
**TS192GSSD25S-M**



Reliability	
Data Reliability	Supports BCH ECC 8 bits or 15 bits in 512 bytes
Data Retention	10 years
MTBF	1,000,000 hours

Vibration	
Operating	3.0G, 5 - 800Hz
Non-Operating	3.0G, 5 - 800Hz

\* Note: Reference to the IEC 60068-2-6 Testing procedures; Operating-Sine wave, 5-800Hz/1 oct., 1.5mm, 3g, 0.5 hr./axis, total 1.5 hrs.

Shock	
Operating	1500G, 0.5ms
Non-Operating	1500G, 0.5ms

\* Note: Reference to the IEC 60068-2-27 Testing procedures; Operating-Half-sine wave, 1500g, 0.5ms, 3 times/dir., total 18 times.

Regulations	
Compliance	CE, FCC and BSMI

**TS8GSSD25S-S**  
**TS16GSSD25S-S/M**  
**TS32GSSD25S-S/M**  
**TS64GSSD25S-S/M**  
**TS128GSSD25S-M**  
**TS192GSSD25S-M**



### Package Dimensions

Below figure illustrates the Transcend 2.5" SATA Solid State Disk. All dimensions are in mm.

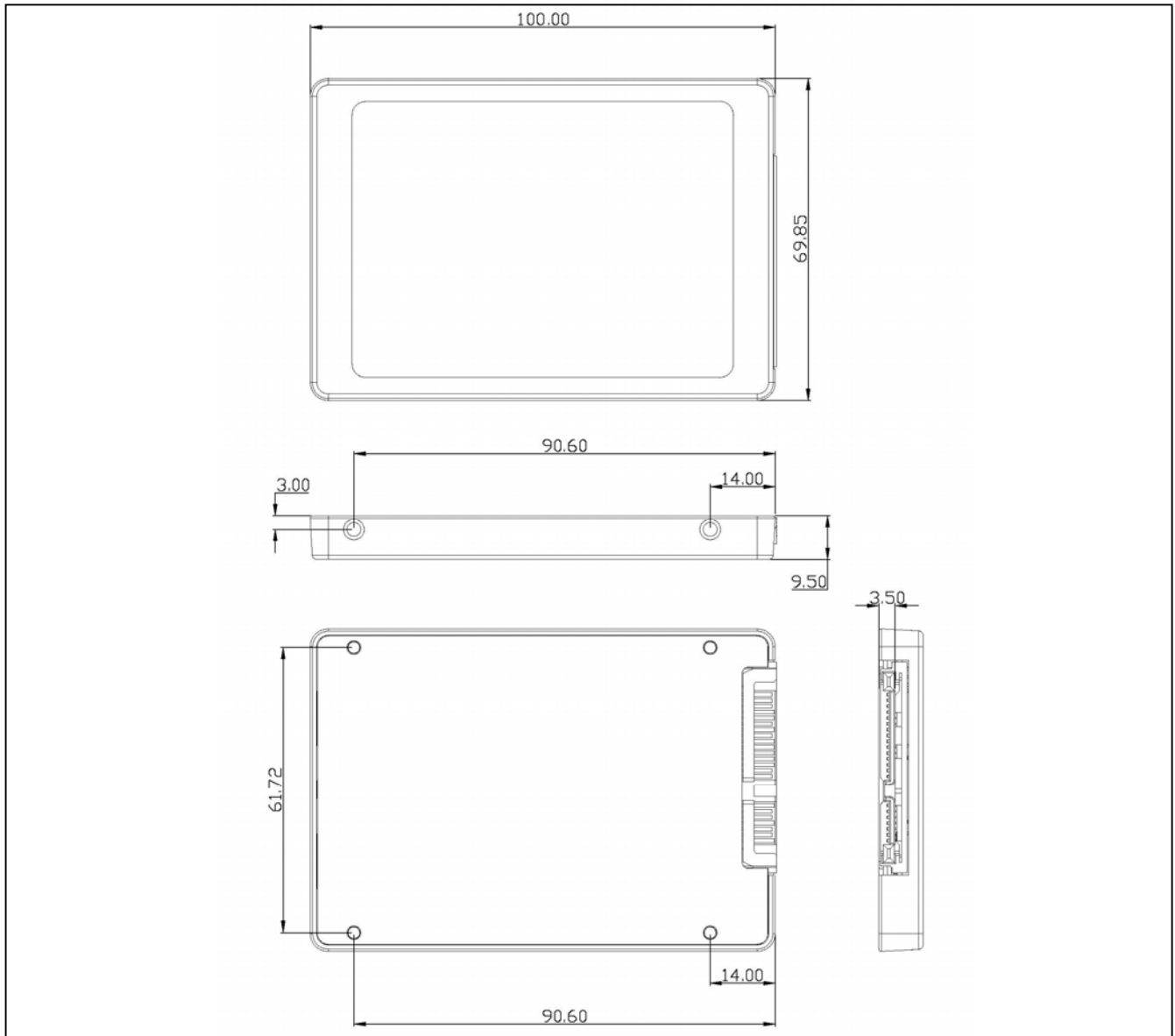

\*Note: Tighten mounting screws with no more than 1.0Kg-cm (0.07ft-lbs) of torque.

**TS8GSSD25S-S**  
**TS16GSSD25S-S/M**  
**TS32GSSD25S-S/M**  
**TS64GSSD25S-S/M**  
**TS128GSSD25S-M**  
**TS192GSSD25S-M**



**Pin Assignments**

Pin No.	Pin Name	Pin No.	Pin Name
01	GND	02	A+
03	A-	04	GND
05	B-	06	B+
07	GND	08	NC
09	NC	10	NC
11	GND	12	GND
13	GND	14	5V
15	5V	16	5V
17	GND	18	GND
19	GND	20	NC
21	NC	22	NC

**Pin Layout**

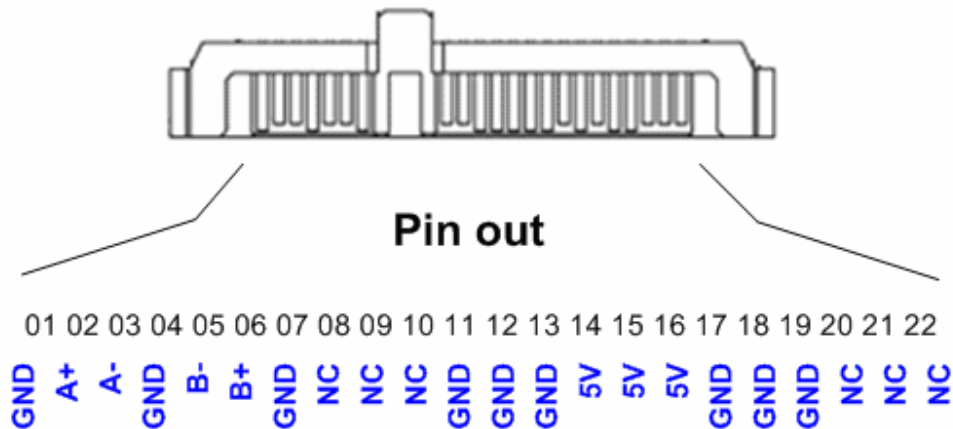

TS8GSSD25S-S  
TS16GSSD25S-S/M  
TS32GSSD25S-S/M  
TS64GSSD25S-S/M  
TS128GSSD25S-M  
TS192GSSD25S-M



Block Diagram

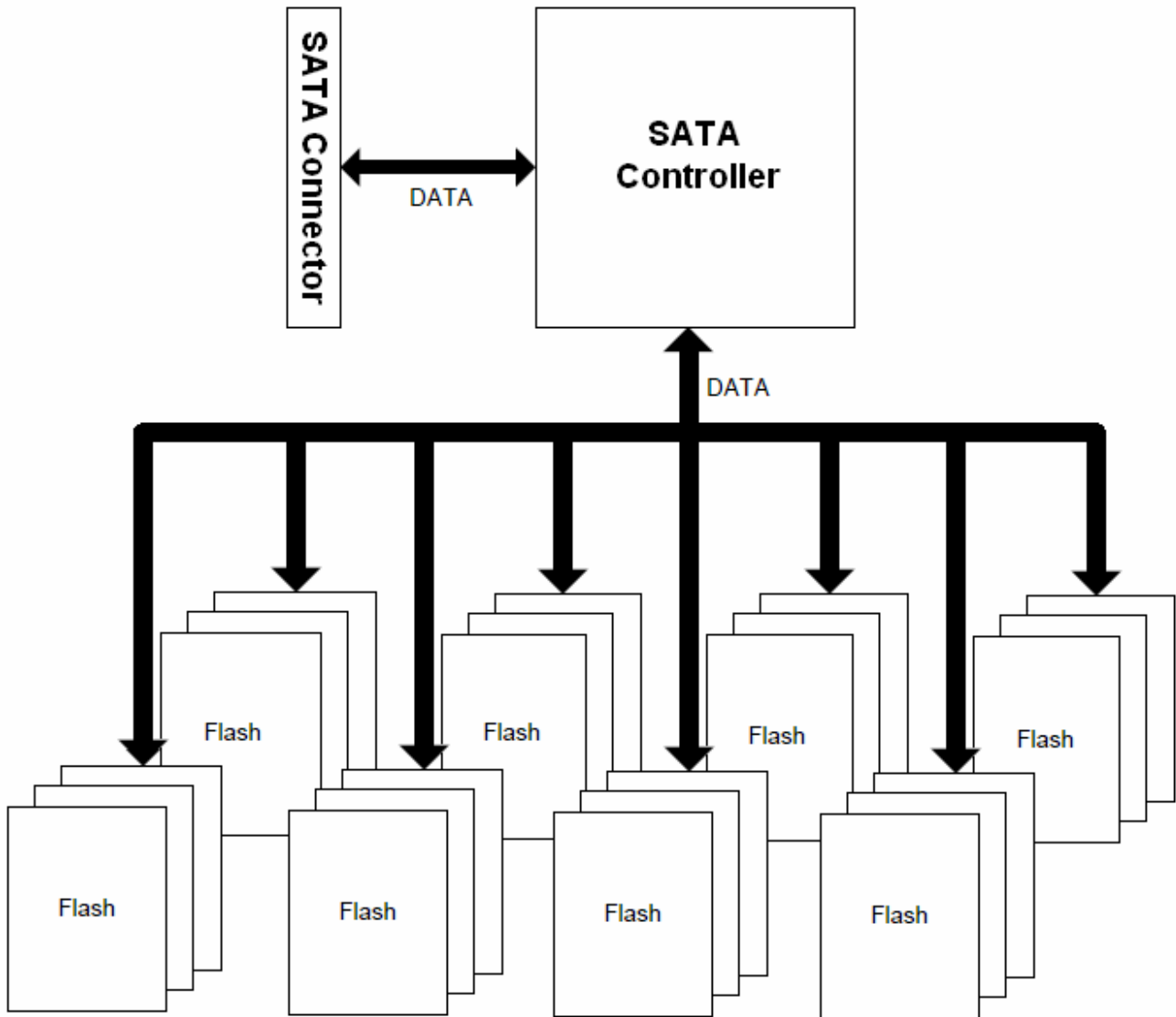

**TS8GSSD25S-S**  
**TS16GSSD25S-S/M**  
**TS32GSSD25S-S/M**  
**TS64GSSD25S-S/M**  
**TS128GSSD25S-M**  
**TS192GSSD25S-M**



---

## Reliability

### **Wear-Leveling algorithm**

The controller supports static/dynamic wear leveling. When the host writes data, the controller will find and use the block with the lowest erase count among the free blocks. This is known as dynamic wear leveling. When the free blocks' erase count is higher than the data blocks', it will activate the static wear leveling, replacing the not so frequently used user blocks with the high erase count free blocks.

### **ECC algorithm**

The controller uses BCH8/BCH15 ECC algorithm per 512 bytes. BCH8/BCH15 can correct up to 8 or 15 random error bits within 512 data bytes.

### **Bad-block management**

When the flash encounters ECC failed, program fail or erase fail, the controller will mark the block as bad block to prevent the used of this block and caused data lost later on.



**TS8GSSD25S-S**  
**TS16GSSD25S-S/M**  
**TS32GSSD25S-S/M**  
**TS64GSSD25S-S/M**  
**TS128GSSD25S-M**  
**TS192GSSD25S-M**



## SATA Interface

### Out of bank signaling

There shall be three Out Of Band (OOB) signals used/detected by the Phy: COMRESET, COMINIT, and COMWAKE. COMINIT, COMRESET and COMWAKE OOB signaling shall be achieved by transmission of either a burst of four Gen1 ALIGN<sub>P</sub> primitives or a burst composed of four Gen1 Dwords with each Dword composed of four D24.3 characters, each burst having a duration of 160 U<sub>l\_oob</sub>. Each burst is followed by idle periods (at common-mode levels), having durations as depicted in Figure 4 and Table 2.

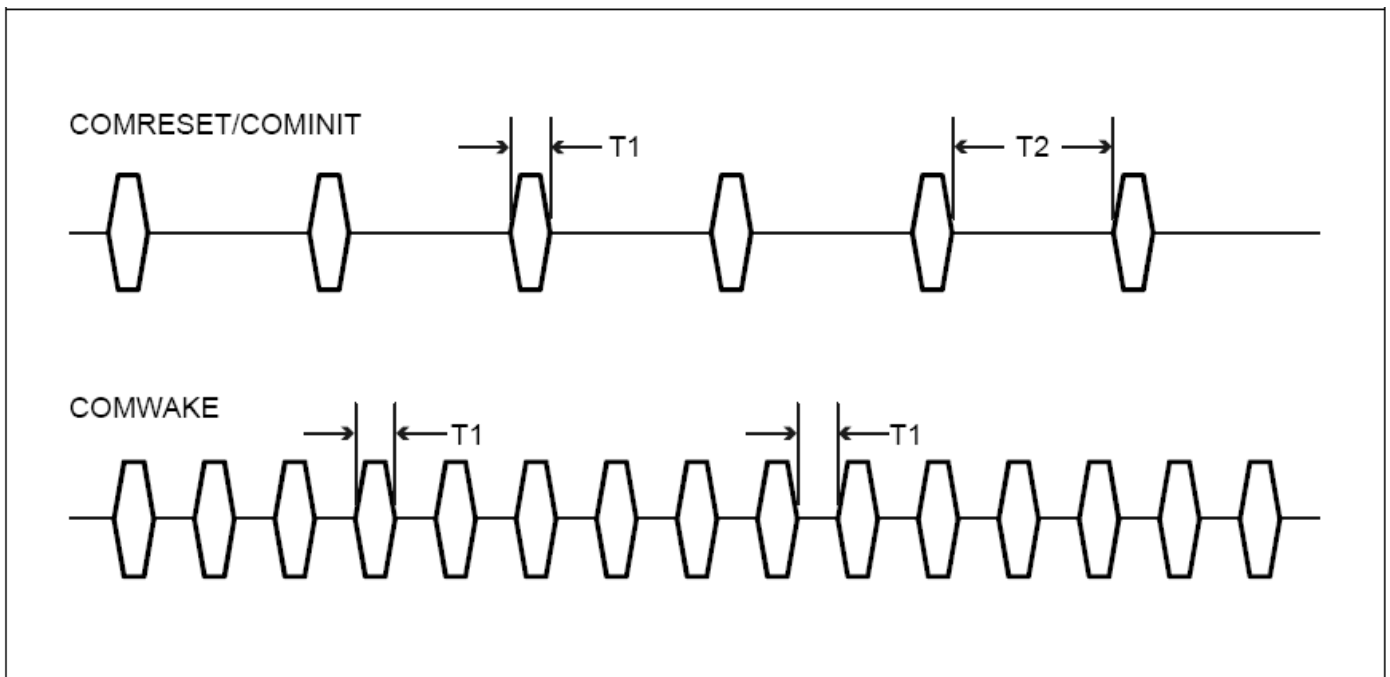

Figure 4: OOB signals

Time	Value
T1	160 U <sub>l_oob</sub> (106.7 ns nominal)
T2	480 U <sub>l_oob</sub> (320 ns nominal)

**TS8GSSD25S-S**  
**TS16GSSD25S-S/M**  
**TS32GSSD25S-S/M**  
**TS64GSSD25S-S/M**  
**TS128GSSD25S-M**  
**TS192GSSD25S-M**



**COMRESET**

COMRESET always originates from the host controller, and forces a hardware reset in the device. It is indicated by transmitting bursts of data separated by an idle bus condition. The OOB COMRESET signal shall consist of no less than six data bursts, including inter-burst temporal spacing. The COMRESET signal shall be:

- 1) Sustained/continued uninterrupted as long as the system hard reset is asserted, or
- 2) Started during the system hardware reset and ended some time after the negation of system hardware reset, or
- 3) Transmitted immediately following the negation of the system hardware reset signal.

The host controller shall ignore any signal received from the device from the assertion of the hardware reset signal until the COMRESET signal is transmitted. Each burst shall be 160 Gen1 UI's long (106.7 ns) and each inter-burst idle state shall be 480 Gen1 UI's long (320 ns). A COMRESET detector looksfor four consecutive bursts with 320 ns spacing (nominal). Any spacing less than 175 ns or greater than 525 ns shall invalidate the COMRESET detector output. The COMRESET interface signal to the Phy layer shall initiate the Reset sequence shown in Figure 5 below. The interface shall be held inactive for at least 525 ns after the last burst to ensure far-end detector detects the negation properly.

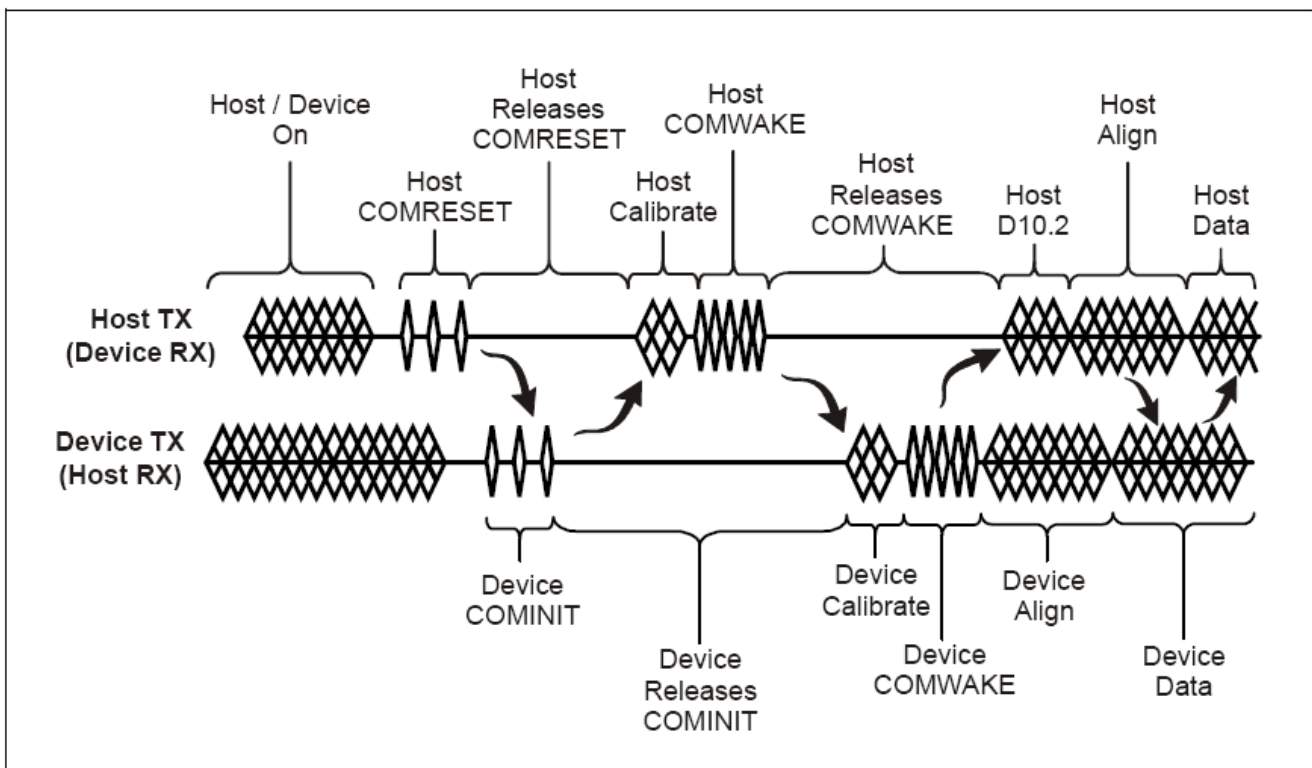

Figure 5 : comreset sequence

**TS8GSSD25S-S**  
**TS16GSSD25S-S/M**  
**TS32GSSD25S-S/M**  
**TS64GSSD25S-S/M**  
**TS128GSSD25S-M**  
**TS192GSSD25S-M**



---

Description:

1. Host/device are powered and operating normally with some form of active communication.
2. Some condition in the host causes the host to issue COMRESET
3. Host releases COMRESET. Once the condition causing the COMRESET is released, the host releases the COMRESET signal and puts the bus in a quiescent condition.
4. Device issues COMINIT – When the device detects the release of COMRESET, it responds with a COMINIT. This is also the entry point if the device is late starting. The device may initiate communications at any time by issuing a COMINIT.
5. Host calibrates and issues a COMWAKE.
6. Device responds – The device detects the COMWAKE sequence on its RX pair and calibrates its transmitter (optional). Following calibration the device sends a six burst COMWAKE sequence and then sends a continuous stream of the ALIGN sequence starting at the device's highest supported speed. After ALIGNP Dwords have been sent for 54.6us (2048 nominal Gen1 Dword times) without a response from the host as determined by detection of ALIGNP primitives received from the host, the device assumes that the host cannot communicate at that speed. If additional speeds are available the device tries the next lower supported speed by sending ALIGNP Dwords at that rate for 54.6 us (2048 nominal Gen1 Dword times.) This step is repeated for as many slower speeds as are supported. Once the lowest speed has been reached without response from the host, the device enters an error state.
7. Host locks – after detecting the COMWAKE, the host starts transmitting D10.2 characters at its lowest supported rate. Meanwhile, the host receiver locks to the ALIGN sequence and, when ready, returns the ALIGN sequence to the device at the same speed as received. A host shall be designed such that it acquires lock in 54.6us (2048 nominal Gen1 Dword times) at any given speed. The host should allow for at least 873.8 us (32768 nominal Gen1 Dword times) after detecting the release of COMWAKE to receive the first ALIGNP. This ensures interoperability with multi-generational and synchronous designs. If no ALIGNP is received within 873.8 us (32768 nominal Gen1 Dword times) the host restarts the power-on sequence – repeating indefinitely until told to stop by the Application layer.
8. Device locks – the device locks to the ALIGN sequence and, when ready, sends SYNCP indicating it is ready to start normal operation.
9. Upon receipt of three back-to-back non-ALIGNP primitives, the communication link is established and normal operation may begin.

**TS8GSSD25S-S**  
**TS16GSSD25S-S/M**  
**TS32GSSD25S-S/M**  
**TS64GSSD25S-S/M**  
**TS128GSSD25S-M**  
**TS192GSSD25S-M**



**COMINIT**

COMINIT always originates from the drive and requests a communication initialization. It is electrically identical to the COMRESET signal except that it originates from the device and is sent to the host. It is used by the device to request a reset from the host in accordance to the sequence shown in Figure 6, below.

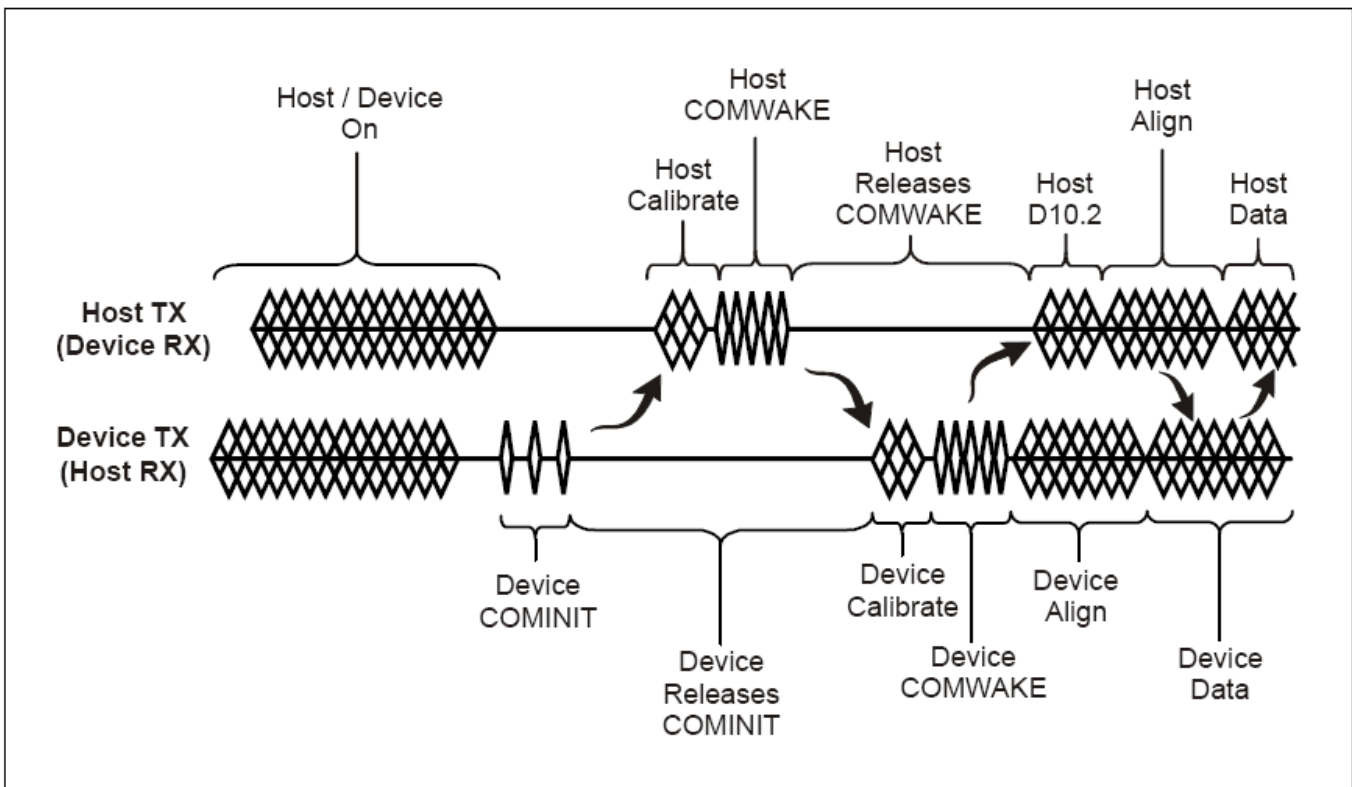

Figure 6 : cominit sequence

Description:

1. Host/device are powered and operating normally with some form of active communication.
2. Some condition in the device causes the device to issues a COMINIT
3. Host calibrates and issues a COMWAKE.
4. Device responds – The device detects the COMWAKE sequence on its RX pair and calibrates its transmitter (optional). Following calibration the device sends a six burst COMWAKE sequence and then sends a continuous stream of the ALIGN sequence starting at the device's highest supported speed. After ALIGN<sub>N</sub> Dwords have been sent for 54.6 us (2048 nominal Gen1 Dword times) without a response from the host as determined by detection of ALIGN<sub>N</sub> primitives received

**TS8GSSD25S-S**  
**TS16GSSD25S-S/M**  
**TS32GSSD25S-S/M**  
**TS64GSSD25S-S/M**  
**TS128GSSD25S-M**  
**TS192GSSD25S-M**

 **Transcend**<sup>®</sup>  
**2.5" Solid State Disk**

---

from the host, the device assumes that the host cannot communicate at that speed. If additional speeds are available the device tries the next lower supported speed by sending ALIGN<sub>P</sub> Dwords at that rate for 54.6 us (2048 nominal Gen1 Dword times.) This step is repeated for as many slower speeds as are supported. Once the lowest speed has been reached without response from the host, the device enters an error state.

5. Host locks – after detecting the COMWAKE, the host starts transmitting D10.2 characters at its lowest supported rate. Meanwhile, the host receiver locks to the ALIGN sequence and, when ready, returns the ALIGN sequence to the device at the same speed as received. A host shall be designed such that it acquires lock in 54.6 us (2048 nominal Gen1 Dword times) at any given speed. The host should allow for at least 873.8 us (32768 nominal Gen1 Dword times) after detecting the release of COMWAKE to receive the first ALIGN<sub>P</sub>. This ensures interoperability with multi-generational and synchronous designs. If no ALIGN<sub>P</sub> is received within 873.8 us (32768 nominal Gen1 Dword times) the host restarts the power-on sequence – repeating indefinitely until told to stop by the Application layer.

6. Device locks – the device locks to the ALIGN sequence and, when ready, sends SYNC<sub>P</sub> indicating it is ready to start normal operation.

6. Upon receipt of three back-to-back non-ALIGN<sub>P</sub> primitives, the communication link is established and normal operation may begin.

**TS8GSSD25S-S**  
**TS16GSSD25S-S/M**  
**TS32GSSD25S-S/M**  
**TS64GSSD25S-S/M**  
**TS128GSSD25S-M**  
**TS192GSSD25S-M**



**Power on sequence timing diagram**

The following timing diagrams and descriptions are provided for clarity and are informative.

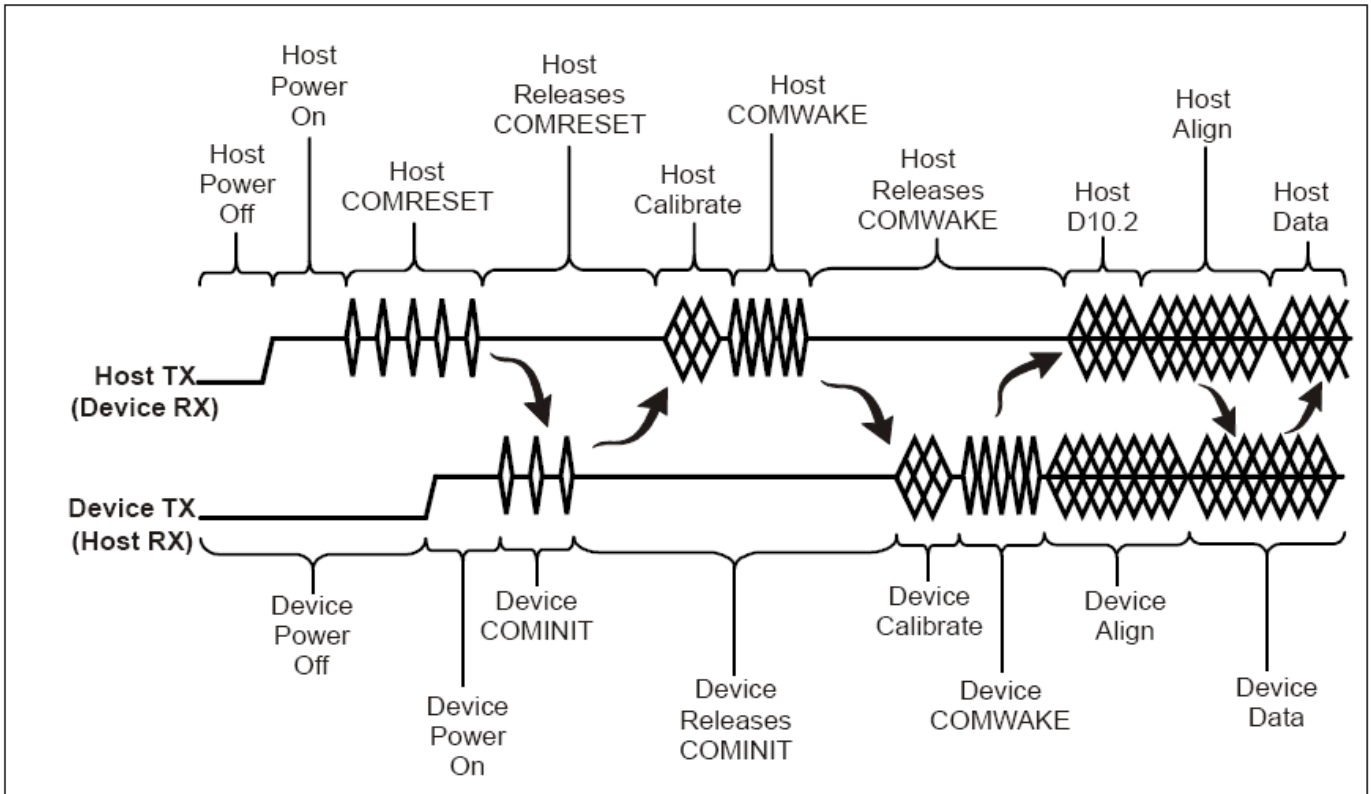

Figure 7: power on sequence

**Description:**

1. Host/device power-off - Host and device power-off.
2. Power is applied - Host side signal conditioning pulls TX and RX pairs to neutral state (common mode voltage).
3. Host issues COMRESET
4. Host releases COMRESET. Once the power-on reset is released, the host releases the COMRESET signal and puts the bus in a quiescent condition.
5. Device issues COMINIT – When the device detects the release of COMRESET, it responds with a COMINIT. This is also the entry point if the device is late starting. The device may initiate communications at any time by issuing a COMINIT.
6. Host calibrates and issues a COMWAKE.
7. Device responds – The device detects the COMWAKE sequence on its RX pair and calibrates its transmitter (optional).

**TS8GSSD25S-S**  
**TS16GSSD25S-S/M**  
**TS32GSSD25S-S/M**  
**TS64GSSD25S-S/M**  
**TS128GSSD25S-M**  
**TS192GSSD25S-M**

 **Transcend**<sup>®</sup>  
**2.5" Solid State Disk**

---

Following calibration the device sends a six burst COMWAKE sequence and then sends a continuous stream of the ALIGN sequence starting at the device's highest supported speed. After ALIGN<sub>P</sub> primitives have been sent for 54.6 us (2048 nominal Gen1 Dword times) without a response from the host as determined by detection of ALIGN<sub>P</sub> primitives received from the host, the device assumes that the host cannot communicate at that speed. If additional speeds are available the device tries the next lower supported speed by sending ALIGN<sub>P</sub> primitives at that rate for 54.6 us (2048 nominal Gen1 Dword times.) This step is repeated for as many slower speeds as are supported. Once the lowest speed has been reached without response from the host, the device shall enter an error state.

8. Host locks – after detecting the COMWAKE, the host starts transmitting D10.2 characters at its lowest supported rate. Meanwhile, the host receiver locks to the ALIGN sequence and, when ready, returns the ALIGN sequence to the device at the same speed as received. A host shall be designed such that it acquires lock in 54.6 us (2048 nominal Gen1 Dword times) at any given speed. The host should allow for at least 873.8 us (32768 nominal Gen1 Dword times) after detecting the release of COMWAKE to receive the first ALIGN<sub>P</sub>. This insures interoperability with multi-generational and synchronous designs. If no ALIGN<sub>P</sub> is received within 873.8 us (32768 nominal Gen1 Dword times) the host restarts the power-on sequence – repeating indefinitely until told to stop by the Application layer.

9. Device locks – the device locks to the ALIGN sequence and, when ready, sends the SYNC<sub>P</sub> primitive indicating it is ready to start normal operation.

10. Upon receipt of three back-to-back non-ALIGN<sub>P</sub> primitives, the communication link is established and normal operation may begin.

**TS8GSSD25S-S**  
**TS16GSSD25S-S/M**  
**TS32GSSD25S-S/M**  
**TS64GSSD25S-S/M**  
**TS128GSSD25S-M**  
**TS192GSSD25S-M**



**ATA command register**

This table with the following paragraphs summarizes the ATA command set.

**Command Table**

Command Name	Code	PARAMETERS USED					
		SC	SN	CY	DR	HD	FT
CHECK POWER MODE	E5h	X	X	X	O	X	X
EXECUTE DIAGNOSTICS	90h	X	X	X	O	X	X
FLUSH CACHE	E7h	X	X	X	O	O	X
FLUSH CACHE EXT	EAh	X	X	X	O	O	X
IDENTIFY DEVICE	ECh	X	X	X	O	X	X
IDLE	E3h	O	X	X	O	X	X
IDLE IMMEDIATE	E1h	X	X	X	O	X	X
INITIALIZE DEVICE PARAMETERS	91h	O	X	X	O	O	X
READ BUFFER	E4h	X	X	X	O	X	X
READ DMA	C8h or C9h	O	O	O	O	O	X
READ DMA EXT	25h	O	O	O	O	O	X
READ FPDMA QUEUED	60h	O	O	O	O	O	O
READ LOG EXT	2Fh	O	O	O	O	O	O
READ MULTIPLE	C4h	O	O	O	O	O	X
READ MULTIPLE EXT	29h	O	O	O	O	O	X
READ SECTOR(S)	20h or 21h	O	O	O	O	O	X
READ SECTOR(S) EXT	24h	O	O	O	O	O	X
READ VERIFY SECTOR(S)	40h or 41h	O	O	O	O	O	X
READ VERIFY SECTOR(S) EXT	42h	O	O	O	O	O	X
RECALIBRATE	10h	X	X	X	O	X	X
SECURITY DISABLE PASSWORD	F6h	X	X	X	O	X	X
SECURITY ERASE PREPARE	F3h	X	X	X	O	X	X
SECURITY ERASE UNIT	F4h	X	X	X	O	X	X
SECURITY FREEZE LOCK	F5h	X	X	X	O	X	X
SECURITY SET PASSWORD	F1h	X	X	X	O	X	X



**TS8GSSD25S-S**  
**TS16GSSD25S-S/M**  
**TS32GSSD25S-S/M**  
**TS64GSSD25S-S/M**  
**TS128GSSD25S-M**  
**TS192GSSD25S-M**



SECURITY UNLOCK	F2h	X	X	X	O	X	X
SEEK	7xh	X	X	O	O	O	X
SET FEATURES	EFh	O	X	X	O	X	O
SET MULTIPLE MODE	C6h	O	X	X	O	X	X
SLEEP	E6h	X	X	X	O	X	X
SMART	B0h	X	X	O	O	X	O
STANDBY	E2h	X	X	X	O	X	X
STANDBY IMMEDIATE	E0h	X	X	X	O	X	X
WRITE BUFFER	E8h	X	X	X	O	X	X
WRITE DMA	CAh or CBh	O	O	O	O	O	X
WRITE DMA EXT	35h	O	O	O	O	O	X
WRITE DMA FUA EXT	3Dh	O	O	O	O	O	X
WRITE FPDMA QUEUED	61h	O	O	O	O	O	O
WRITE MULTIPLE	C5h	O	O	O	O	O	X
WRITE MULTIPLE EXT	39h	O	O	O	O	O	X
WRITE MULTIPLE FUA EXT	CEh	O	O	O	O	O	X
WRITE SECTOR(S)	30h or 31h	O	O	O	O	O	X
WRITE SECTOR(S) EXT	34h	O	O	O	O	O	X

**Note:**

O = Valid, X = Don't care

SC = Sector Count Register

SN = Sector Number Register

CY = Cylinder Low/High Register

DR = DEVICE SELECT Bit (DEVICE/HEAD Register Bit 4)

HD = HEAD SELECT Bit (DEVICE/HEAD Register Bit 3-0)

FT = Features Register

**TS8GSSD25S-S**  
**TS16GSSD25S-S/M**  
**TS32GSSD25S-S/M**  
**TS64GSSD25S-S/M**  
**TS128GSSD25S-M**  
**TS192GSSD25S-M**



---

## ATA Command Specifications

### **CHECK POWER MODE (E5h)**

The host can use this command to determine the current power management mode.

### **EXECUTE DIAGNOSTICS (90h)**

This command performs the internal diagnostic tests implemented by the drive.

### **FLUSH CACHE (E7h)**

This command is used by the host to request the device to flush the write cache. If there is data in the write cache, that data shall be written to the media. The BSY bit shall remain set to one until all data has been successfully written or an error occurs.

### **FLUSH CACHE EXT (EAh)**

48-bit feature set mandatory command. This command is used by the host to request the device to flush the write cache. If there is data in the write cache, that data shall be written to the media. The BSY bit shall remain set to one until all data has been successfully written or an error occurs.

### **IDENTIFY DEVICE (ECh)**

This commands read out 512Bytes of drive parameter information. Parameter Information consists of the arrangement and value as shown in the following table. This command enables the host to receive the Identify Drive Information from the device.

**TS8GSSD25S-S**  
**TS16GSSD25S-S/M**  
**TS32GSSD25S-S/M**  
**TS64GSSD25S-S/M**  
**TS128GSSD25S-M**  
**TS192GSSD25S-M**



**Identify Device Information Default Value**

Word	Value	F/V	Description
0	0040h	F X X X V X	General configuration bit-significant information: 15 0 = ATA device 14-8 Retired 7-6 Obsolete 5-3 Retired 2 Reserved 1 Retired 0 Reserved
1	3C8Ah 3FFFh	F	Number of logical cylinders 15498 (8GB capacity) 16383 (above 16GB capacity)
2	C837h	V	Specific configuration
3	0010h	F	Number of logical heads
4-5	0000h	X	Retired
6	003Fh	F	Number of logical sector per logical track
7-8	0000h		Reserved for assignment by the CompactFlash_ Association
9	0000h	X	Retired
10-19	XXXXh	F	Serial number (20 ASCII characters)
20-21	0000h	X	Retired
22	0000h	X	Obsolete
23-26	XXXXh	F	Firmware revision (8 ASCII characters)
27-46	XXXXh	F	Model number (40 ASCII characters)
47	8001h	F F F	15-8 80h 7-0 00h = Reserved 01h = Maximum number of 1 sectors on READ/WRITE MULTIPLE commands
48	0000h	F	Reserved
49	2F00h	F F F F F X	Capabilities 15-14 Reserved for the IDENTIFY PACKET DEVICE command. 13 1 = Standby timer values as specified in this standard are supported 0 = Standby timer values shall be managed by the device 12 Reserved for the IDENTIFY PACKET DEVICE command. 11 1 = IORDY supported 0 = IORDY may be supported 10 1 = IORDY may be disabled 9 1 = LBA supported 8 1 = DMA supported. 7-0 Retired
50	4000h	F F X F	Capabilities 15 Shall be cleared to zero. 14 Shall be set to one. 13-2 Reserved. 1 Obsolete 0 Shall be set to one to indicate a device specific Standby timer value minimum.

**TS8GSSD25S-S**  
**TS16GSSD25S-S/M**  
**TS32GSSD25S-S/M**  
**TS64GSSD25S-S/M**  
**TS128GSSD25S-M**  
**TS192GSSD25S-M**



51	0000h	F	15-8 PIO data transfer cycle timing mode 7-0 Reserved
52	0000h	X	Obsolete
53	0007h	F F F X	15-3 Reserved 2 1 = the fields reported in word 88 are valid 0 = the fields reported in word 88 are not valid 1 1 = the fields reported in words 70:64 are valid 0 = the fields reported in words 70:64 are not valid 0 1 = the fields reported in words 58:54 are valid 0 = the fields reported in words 58:54 are not valid
54	XXXXh	X	Number of current cylinders
55	00XXh	X	Number of current heads
56	XXXXh	X	Number of current sector per track
57-58	XXXXh	X	Current capacity in sectors
59	0101h	V V	15-9 Reserved 8 1 = Multiple sector setting is valid 7-0 xxh = Setting for number of sectors that shall be transferred per interrupt on R/W Multiple command
60-61	XXXXh	F	Total number of user addressable sectors
62	0000h	X	Obsolete
63	0007h	F V V V F F F	15-11 Reserved 10 1 = Multiword DMA mode 2 is selected 0 = Multiword DMA mode 2 is not selected 9 1 = Multiword DMA mode 1 is selected 0 = Multiword DMA mode 1 is not selected 8 1 = Multiword DMA mode 0 is selected 0 = Multiword DMA mode 0 is not selected 7-3 Reserved 2 1 = Multiword DMA mode 2 and below are supported 1 1 = Multiword DMA mode 1 and below are supported 0 1 = Multiword DMA mode 0 is supported
64	0003h	F	15-8 Reserved 7-0 Advanced PIO modes supported
65	0078h	F	Minimum Multiword DMA transfer cycle time per word
66	0078h	F	Manufacturer's recommended Multiword DMA transfer cycle time
67	0078h	F	Minimum PIO transfer cycle time without flow control
68	0078h	F	Minimum PIO transfer cycle time with IORDY flow control
69-70	0000h		Reserved
71-74	0000h		Reserved for the IDENTIFY PACKET DEVICE command
75	0000h	F	Queue depth 15-5 Reserved 4-0 Maximum queue depth - 1

**TS8GSSD25S-S**  
**TS16GSSD25S-S/M**  
**TS32GSSD25S-S/M**  
**TS64GSSD25S-S/M**  
**TS128GSSD25S-M**  
**TS192GSSD25S-M**



76	0106h	F F F F F F F	Serial ATA Capabilities 15-11 Reserved for Serial ATA 10 1 = Supports Phy Event Counts 9 1 = Supports receipt of host initiated power management requests 8 1 = Supports the NCQ feature set 7-3 Reserved for Serial ATA 2 1 = Supports SATA Gen2 Signaling Speed (3.0Gb/s) 1 1 = Supports SATA Gen1 Signaling Speed (1.5Gb/s) 0 Shall be cleared to zero
77	0000h		Reserved for Serial ATA
78	0004h	F F F F F F	Serial ATA feature supported 15-7 Reserved for Serial ATA 6 1 = Device supports Software Settings Preservation 5 Reserved for Serial ATA 4 1 = Device supports in-order data delivery 3 1 = Device supports initiating power management 2 1 = Device supports DMA Setup auto-activation 1 1 = Device supports non-zero buffer offsets 0 Shall be cleared to zero
79	0000h	V V V V V F	Serial ATA feature enabled 15-7 Reserved for Serial ATA 6 1 = Software Settings Preservation enabled 5 Reserved for Serial ATA 4 1 = In-order data delivery enabled 3 1 = Device initiated power management enabled 2 1 = DMA Setup auto-activation enabled 1 1 = Non-zero buffer offsets enabled 0 Shall be cleared to zero
80	00F0h	F F F F F F F F F F F X X X	Major version number 0000h or FFFFh = device does not report version 15 Reserved 14 Reserved for ATA/ATAPI-14 13 Reserved for ATA/ATAPI-13 12 Reserved for ATA/ATAPI-12 11 Reserved for ATA/ATAPI-11 10 Reserved for ATA/ATAPI-10 9 Reserved for ATA/ATAPI-9 8 Reserved for ATA/ATAPI-8 7 1 = supports ATA/ATAPI-7 6 1 = supports ATA/ATAPI-6 5 1 = supports ATA/ATAPI-5 4 1 = supports ATA/ATAPI-4 3 Obsolete 2 Obsolete 1 Obsolete 0 Reserved

**TS8GSSD25S-S**  
**TS16GSSD25S-S/M**  
**TS32GSSD25S-S/M**  
**TS64GSSD25S-S/M**  
**TS128GSSD25S-M**  
**TS192GSSD25S-M**



81	0000h	F	Minor version number
82	304Bh		Command and feature sets supported
		X	15 Obsolete
		F	14 1 = NOP command supported
		F	13 1 = READ BUFFER command supported
		F	12 1 = WRITE BUFFER command supported
		X	11 Obsolete
		F	10 1 = Host Protected Area feature set supported
		F	9 1 = DEVICE RESET command supported
		F	8 1 = SERVICE interrupt supported
		F	7 1 = release interrupt supported
		F	6 1 = look-ahead supported
		F	5 1 = write cache supported
		F	4 Shall be cleared to zero to indicate that the PACKET Command feature set is not supported.
		F	3 1 = mandatory Power Management feature set supported
F	2 1 = Removable Media feature set supported		
F	1 1 = Security Mode feature set supported		
F	0 1 = SMART feature set supported		
83	7400h		Command and feature sets supported
		F	15 Shall be cleared to zero
		F	14 Shall be set to one
		F	13 1 = The FLUSH CACHE EXT command is supported
		F	12 Shall be set to one to indicate that the mandatory FLUSH CACHE command is supported
		F	11 1 = The DCO feature set is supported
		F	10 1 = The 48-bit Address feature set is supported
		F	9 1 = The AAM feature set is supported
		F	8 1 = SET MAX security extension supported
			7 Reserved
		F	6 1 = SET FEATURES subcommand required to spinup after power-up
		F	5 1 = Power-Up In Standby feature set supported
		F	4 1 = Removable Media Status Notification feature set supported
		F	3 1 = Advanced Power Management feature set supported
F	2 1 = CFA feature set supported		
F	1 1 = READ/WRITE DMA QUEUED supported		
F	0 1 = DOWNLOAD MICROCODE command supported		
84	4060h		Command and feature sets supported
		F	15 Shall be cleared to zero
		F	14 Shall be set to one
		F	13 1 = The IDLE IMMEDIATE command with UNLOAD feature is supported
			12-11 Reserved for TLC
		X	10-9 Obsolete
		F	8 1 = The 64-bit World wide name is supported
		F	7 1 = The WRITE DMA QUEUED FUA EXT command is supported
		F	6 1 = The WRITE DMA FUA EXT and WRITE MULTIPLE FUA EXT commands are supported
		F	5 1 = The GPL feature set is supported
F	4 1 = The Streaming feature set is supported		

**TS8GSSD25S-S**  
**TS16GSSD25S-S/M**  
**TS32GSSD25S-S/M**  
**TS64GSSD25S-S/M**  
**TS128GSSD25S-M**  
**TS192GSSD25S-M**



		F	3	1 = The Media Card Pass Through Command feature set is supported
		F	2	1 = Media serial number is supported
		F	1	1 = SMART self-test supported
		F	0	1 = SMART error logging supported
85	3069h	X	15	Obsolete
		F	14	1 = The NOP command is supported
		F	13	1 = The READ BUFFER command is supported
		F	12	1 = The WRITE BUFFER command is supported
		X	11	Obsolete
		V	10	1 = HPA feature set is supported
		F	9	Shall be cleared to zero to indicate that the DEVICE RESET command is not supported
		V	8	1 = The SERVICE interrupt is enabled
		V	7	1 = The release interrupt is enabled
		V	6	1 = Read look-ahead is enabled
		V	5	1 = The volatile write cache is enabled
		F	4	Shall be cleared to zero to indicate that the PACKET Command feature set is not supported.
		F	3	Shall be set to one to indicate that the mandatory Power Management feature is supported
		X	2	Obsolete
		V	1	1 = The Security feature set is enabled
		V	0	1 = The SMART feature set is enabled
86	3400h	F	15	1 = Words 119-120 are valid
			14	Reserved
		F	13	1 = FLUSH CACHE EXT command supported
		F	12	1 = FLUSH CACHE command supported
		F	11	1 = The DCO feature set is supported
		F	10	1 = The 48-bit Address feature set is supported
		V	9	1 = The AAM feature set is enable
		V	8	1 = The SET MAX security extension is enabled by SET MAX SET PASSWORD
			7	Reserved for Address Offset Reserved Area Boot Method
		F	6	1 = SET FEATURES subcommand required to spin-up after power-up
		V	5	1 = The PUIS feature set is enabled
		X	4	Obsolete
		V	3	1 = The APM feature set is enabled
		F	2	1 = The CFA feature set is supported
		F	1	1 = The TCQ feature set is supported
		F	0	1 = The DOWNLOAD MICROCODE command is supported
87	4060h	F	15	Shall be cleared to zero
		F	14	Shall be set to one
		F	13	1 = The IDLE IMMEDIATE command with UNLOAD feature is supported
			12-11	Reserved for TLC
		X	10-9	Obsolete
		F	8	1 = The 64-bit World wide name is supported
		F	7	1 = The WRITE DMA QUEUED FUA EXT command is supported

**TS8GSSD25S-S**  
**TS16GSSD25S-S/M**  
**TS32GSSD25S-S/M**  
**TS64GSSD25S-S/M**  
**TS128GSSD25S-M**  
**TS192GSSD25S-M**



		F	6	1 = The WRITE DMA FUA EXT and WRITE MULTIPLE FUA EXT commands are supported
		F	5	1 = The GPL feature set is supported
		X	4	Obsolete
		V	3	1 = The Media Card Pass Through Command feature set is supported
		V	2	1 = Media serial number is supported
		F	1	1 = SMART self-test supported
		F	0	1 = SMART error logging supported
88	XX7Fh			Ultra DMA modes (XX depends on the host selecting)
		V	15	Reserved
		V	14	1 = Ultra DMA mode 6 is selected 0 = Ultra DMA mode 6 is not selected
		V	13	1 = Ultra DMA mode 5 is selected 0 = Ultra DMA mode 5 is not selected
		V	12	1 = Ultra DMA mode 4 is selected 0 = Ultra DMA mode 4 is not selected
		V	11	1 = Ultra DMA mode 3 is selected 0 = Ultra DMA mode 3 is not selected
		V	10	1 = Ultra DMA mode 2 is selected 0 = Ultra DMA mode 2 is not selected
		V	9	1 = Ultra DMA mode 1 is selected 0 = Ultra DMA mode 1 is not selected
		V	8	1 = Ultra DMA mode 0 is selected 0 = Ultra DMA mode 0 is not selected
			7	Reserved
		F	6	1 = Ultra DMA mode 6 and below are supported
		F	5	1 = Ultra DMA mode 5 and below are supported
		F	4	1 = Ultra DMA mode 4 and below are supported
		F	3	1 = Ultra DMA mode 3 and below are supported
		F	2	1 = Ultra DMA mode 2 and below are supported
		F	1	1 = Ultra DMA mode 1 and below are supported
		F	0	1 = Ultra DMA mode 0 is supported
89	0001h		15-8	Reserved
		F	7-0	Time required for Normal Erase mode SECURITY ERASE UNIT command
90	0001h		15-8	Reserved
		F	7-0	Time required for Enhanced Erase mode SECURITY ERASE UNIT command
91	0000h	V		Current APM level value
92	FFFEh	V		Master Password Identifier
93	0000h	X		Hardware reset result
94	0000h	F		Current AAM value
		V	15-8	Vendor's recommended AAM value
		V	7-0	Current AAM value
95-99	0000h			Reserved
100-103	XXXXh	X		Total Number of User Addressable Logical Sectors for 48-bit commands (QWord)
104-105	0000h			Reserved



**TS8GSSD25S-S**  
**TS16GSSD25S-S/M**  
**TS32GSSD25S-S/M**  
**TS64GSSD25S-S/M**  
**TS128GSSD25S-M**  
**TS192GSSD25S-M**



106	4000h	F	Physical sector size / logical sector size
		F	15 Shall be cleared to zero
		F	14 Shall be set to one
		F	13 1 = Device has multiple logical sectors per physical sector
		F	12 1 = Device Logical Sector longer than 256 Words
			11-4 Reserved
		F	3-0 2x logical sectors per physical sector
107-118	0000h		Reserved
119	4000h	F	Commands and feature sets supported (Continued from words 84:82)
		F	15 Shall be cleared to zero
		F	14 Shall be set to one
			13-6 Reserved
		F	5 1= The Free-fall Control feature set is supported
		F	4 1 = The DOWNLOAD MICROCODE command with mode 3 is supported
		F	3 1 = The READ LOG DMA EXT and WRITE LOG DMA EXT commands are supported
		F	2 1 = The WRITE UNCORRECTABLE EXT command is supported
		F	1 1 = The Write-Read-Verify feature set is supported
			0 Reserved for DDT
120	4000h	F	Commands and feature sets supported or enabled (Continued from words 87:85)
		F	15 Shall be cleared to zero
		F	14 Shall be set to one
			13-6 Reserved
		V	5 1= The Free-fall Control feature set is enabled
		F	4 1 = The DOWNLOAD MICROCODE command with mode 3 is supported
		F	3 1 = The READ LOG DMA EXT and WRITE LOG DMA EXT commands are supported
		F	2 1 = The WRITE UNCORRECTABLE EXT command is supported
		V	1 1 = The Write-Read-Verify feature set is enabled
			0 Reserved for DDT
121-126	0000h		Reserved for expended supported and enabled settings
127	0000h	X	Obsolete
128	0021h	F	Security status
		V	15-9 Reserved
		V	8 Security level 0 = High, 1 = Maximum
		F	7-6 Reserved
		F	5 1 = Enhanced security erase supported
		V	4 1 = Security count expired
		V	3 1 = Security frozen
		V	2 1 = Security locked
		V	1 1 = Security enabled
		F	0 1 = Security supported
129-159	0000h	X	Vendor specific
160-216	0000h		Reserved
217	0001h	F	Nominal media rotation rate

**TS8GSSD25S-S**  
**TS16GSSD25S-S/M**  
**TS32GSSD25S-S/M**  
**TS64GSSD25S-S/M**  
**TS128GSSD25S-M**  
**TS192GSSD25S-M**



218-254	0000h		Reserved
255	0000h	X	Integrity word 15-8 Checksum 7-0 Signature

Key:

F/V = Fixed/variable content

F = the content of the word is fixed and does not change. For removable media devices, these values may change when media is removed or changed.

V = the contents of the word is variable and may change depending on the state of the device or the commands executed by the device.

X = the content of the word may be fixed or variable.

#### **IDLE (E3h)**

This command causes the device to set BSY, enter the Idle mode, clear BSY and generate an interrupt. If sector count is non-zero, the automatic power down mode is enabled. If the sector count is zero, the automatic power mode is disabled.

#### **IDLE IMMEDIATE (E1h)**

This command causes the device to set BSY, enter the Idle(Read) mode, clear BSY and generate an interrupt.

#### **INITIALIZE DEVICE PARAMETERS (91h)**

This command enables the host to set the number of sectors per track and the number of tracks per heads.

#### **READ BUFFER (E4h)**

The READ BUFFER command enables the host to read a 512-byte block of data.

#### **READ DMA (C8h)**

Read data from sectors during Ultra DMA and Multiword DMA transfer. Use the SET FEATURES command to specify the mode value. A sector count of zero requests 256 sectors.

#### **READ DMA EXT (25h)**

48-bit feature set mandatory command. Read data from sectors during Ultra DMA and Multiword DMA transfer. Use the SET FEATURES command to specify the mode value. A sector count of zero requests 65536 sectors.

#### **READ FPDMA QUEUED (60h)**

NCQ feature set mandatory 48-bit command. This command requests that data to be transferred from the device to the host.

**TS8GSSD25S-S**  
**TS16GSSD25S-S/M**  
**TS32GSSD25S-S/M**  
**TS64GSSD25S-S/M**  
**TS128GSSD25S-M**  
**TS192GSSD25S-M**



---

#### **READ LOG EXT (2Fh)**

General purpose logging feature set mandatory 48-bit command. This command returns the specified log to the host.

<b>Log Address</b>	<b>Log Name</b>	<b>Feature Set</b>	<b>R/W</b>	<b>Access</b>
00h	Log directory	N/A	RO	GPL
10h	NCQ Command Error	NCQ	RO	GPL

#### **READ MULTIPLE (C4h)**

This command performs similarly to the Read Sectors command. Interrupts are not generated on each sector, but on the transfer of a block which contains the number of sectors defined by a Set Multiple command.

#### **READ MULTIPLE EXT (29h)**

48-bit feature set mandatory command. This command performs similarly to the Read Sectors command. Interrupts are not generated on each sector, but on the transfer of a block which contains the number of sectors defined by a Set Multiple command.

#### **READ SECTOR(S) (20h/21h)**

This command reads 1 to 256 sectors as specified in the Sector Count register from sectors which is set by Sector number register. A sector count of 0 requests 256 sectors. The transfer beings specified in the Sector Number register.

#### **READ SECTOR(S) EXT (24h)**

48-bit feature set mandatory command. This command reads 1 to 65536 sectors as specified in the Sector Count register from sectors which is set by Sector number register. A sector count of zero requests 65536 sectors. The transfer beings specified in the Sector Number register.

#### **READ VERIFY SECTOR(S) (40h/41h)**

This command verifies one or more sectors on the drive by transferring data from the flash media to the data buffer in the drive and verifying that the ECC is correct. This command is identical to the Read Sectors command, except that DRQ is never set and no data is transferred to the host.

#### **READ VERIFY SECTOR(S) EXT (42h)**

48-bit feature set mandatory command. This command verifies one or more sectors on the drive by transferring data from the flash media to the data buffer in the drive and verifying that the ECC is correct. This command is identical to the Read Sectors command, except that DRQ is never set and no data is transferred to the host.

**TS8GSSD25S-S**  
**TS16GSSD25S-S/M**  
**TS32GSSD25S-S/M**  
**TS64GSSD25S-S/M**  
**TS128GSSD25S-M**  
**TS192GSSD25S-M**



---

#### **RECALIBRATE (10h)**

The current drive performs no processing if it receives this command. It is supported for backward compatibility with previous devices.

#### **SECURITY DISABLE PASSWORD (F6h)**

Disables any previously set user password and cancels the lock. The host transfers 512 bytes of data, as shown in the following table, to the drive. The transferred data contains a user or master password, which the drive compares with the saved password. If they match, the drive cancels the lock. The master password is still saved. It is re-enabled by issuing the SECURITY SET PASSWORD command to re-set a user password.

#### **SECURITY ERASE PREPARE (F3h)**

This command shall be issued immediately before the Security Erase Unit command to enable erasing and unlocking. This command prevents accidental loss of data on the drive.

#### **SECURITY ERASE UNIT (F4h)**

The host uses this command to transfer 512 bytes of data, as shown in the following table, to the drive. The transferred data contains a user or master password, which the drive compares with the saved password. If they match, the drive deletes user data, disables the user password, and cancels the lock. The master password is still saved. It is re-enabled by issuing the SECURITY SET PASSWORD command to re-set a user password.

**TS8GSSD25S-S**  
**TS16GSSD25S-S/M**  
**TS32GSSD25S-S/M**  
**TS64GSSD25S-S/M**  
**TS128GSSD25S-M**  
**TS192GSSD25S-M**



**SECURITY FREEZE LOCK (F5h)**

Causes the drive to enter Frozen mode. Once this command has been executed, the following commands to update a lock result in the Aborted Command error:

- SECURITY SET PASSWORD
- SECURITY UNLOCK
- SECURITY DISABLE PASSWORD
- SECURITY ERASE PREPARE
- SECURITY ERASE UNIT

The drive exits from Frozen mode upon a power-off or hard reset. If the SECURITY FREEZE LOCK command is issued when the drive is placed in Frozen mode, the drive executes the command, staying in Frozen mode.

**SECURITY SET PASSWORD (F1h)**

This command set user password or master password. The host outputs sector data with PIO data-out protocol to indicate the information defined in the following table.

**Security set Password data content**

Word	Content		
0	Control word		
	Bit 0	Identifier	0=set user password 1=set master password
	Bits 1-7	Reserved	
	Bit 8	Security level	0=High 1=Maximum
	Bits 9-15	Reserved	
1-16	Password (32 bytes)		
17-255	Reserved		

**SECURITY UNLOCK (F2h)**

This command disable LOCKED MODE of the device. This command transfers 512 bytes of data from the host with PIO data-out protocol. The following table defines the content of this information.

**TS8GSSD25S-S**  
**TS16GSSD25S-S/M**  
**TS32GSSD25S-S/M**  
**TS64GSSD25S-S/M**  
**TS128GSSD25S-M**  
**TS192GSSD25S-M**



**Security Unlock information**

Word	Content		
0	Control word		
	Bit 0	Identifier	0=compare user password 1=compare master password
	Bits 1-15	Reserved	
1-16	Password (32 bytes)		
17-255	Reserved		

**SEEK (7xh)**

This command is effectively a NOP command to the device although it does perform a range check.

**SET FEATURES (EFh)**

This command set parameter to Features register and set drive's operation. For transfer mode, parameter is set to Sector Count register. This command is used by the host to establish or select certain features.

**Features register Value and settable operating mode**

Value	Function
02h	Enable write cache
03h	Set transfer mode based on value in Sector Count register.
55h	Disable read look-ahead feature
82h	Disable write cache
AAh	Enable read look-ahead feature

**SET MULTIPLE MODE (C6h)**

This command enables the device to perform READ MULTIPLE and WRITE MULTIPLE operations and establishes the block count for these commands.

**SLEEP (E6h)**

This command causes the device to set BSY, enter the Sleep mode, clear BSY and generate an interrupt.

**TS8GSSD25S-S**  
**TS16GSSD25S-S/M**  
**TS32GSSD25S-S/M**  
**TS64GSSD25S-S/M**  
**TS128GSSD25S-M**  
**TS192GSSD25S-M**



---

#### SMART Function Set (B0h)

Performs different processing required for predicting device failures, according to the subcommand specified in the Features register. If the Features register contains an unsupported value, the Aborted Command error is returned. If the SMART function is disabled, any subcommand other than SMART ENABLE OPERATIONS results in the Aborted Command error.

Code	Smart Subcommand
D0h	READ DATA
D1h	READ ATTRIBUTE THRESHOLDS
D2h	ENABLE/DISABLE ATTRIBUTE AUTOSAVE
D3h	SAVE ATTRIBUTE VALUES
D5h	Reserved
D6h	Reserved
D8h	ENABLE OPERATIONS
D9h	DISABLE OPERATIONS
DAh	RETURN STATUS

**TS8GSSD25S-S**  
**TS16GSSD25S-S/M**  
**TS32GSSD25S-S/M**  
**TS64GSSD25S-S/M**  
**TS128GSSD25S-M**  
**TS192GSSD25S-M**



**SMART READ DATA**

This command returns 512-byte SMART Data Structure to the host with PIO data-in protocol. The register file has to contain D0h for Features register, 4Fh for LBA Mid register and C2h for the LBA High register.

Byte	Description
0-1	Data structure revision number
2-13	1st attribute data
14-361	2nd-30th Individual attribute data
362	Off-line data collection status
363	Reserved
364-365	Total time in seconds to complete off-line data collection
366	Reserved
367	Off-line data collection capability
368-369	SMART capability
370-385	Reserved
386-510	Reserved
511	Data structure Checksum

**Byte 2-361: Individual attribute data**

Byte	Description
0	Attribute ID
1-2	Status Flag (0x0002)
3	Attribute Value (0x64)
4-11	Vendor Specific



**TS8GSSD25S-S**  
**TS16GSSD25S-S/M**  
**TS32GSSD25S-S/M**  
**TS64GSSD25S-S/M**  
**TS128GSSD25S-M**  
**TS192GSSD25S-M**



The attribute ID information is listed in the following table

ID	Description	Detail Information	
		Byte	Description
E5h	Halt System ID, Flash ID	0	Halt System ID
		1	Flash ID (byte 1)
		2	Flash ID (byte 2)
		3	Flash ID (byte 3)
		4	Flash ID (byte 4)
		5	Flash ID (byte 5)
		6	Flash ID (byte 6)
		7	Flash ID (byte 7)
E8h	Firmware version information	0	Year (High Byte, ASCII)
		1	Year (Low Byte, ASCII)
		2	Month (High Byte, ASCII)
		3	Month (Low Byte, ASCII)
		4	Day (High Byte, ASCII)
		5	Day (Low Byte, ASCII)
		6	Channels (binary)
		7	Banks (binary)
E9h	ECC Fail Record	0	ECC fail number
		1	Row address 3
		2	Row address 2
		3	Row address 1
		4	Channel number of last ECC fail
		5	Bank number of last ECC fail
		6	Reserved
		7	Reserved
EAh	Average Erase Count, Max Erase Count	0	Average Erase Count (High Byte)
		1	Average Erase Count
		2	Average Erase Count (Low Byte)
		3	Max Erase Count (High Byte)

**TS8GSSD25S-S**  
**TS16GSSD25S-S/M**  
**TS32GSSD25S-S/M**  
**TS64GSSD25S-S/M**  
**TS128GSSD25S-M**  
**TS192GSSD25S-M**



		4	Max Erase Count
		5	Max Erase Count (Low Byte)
		6	Reserved
		7	Reserved
EBh	Good Block Count, System Block Count	0	Good Block Count (High Byte)
		1	Good Block Count
		2	Good Block Count (Low Byte)
		3	System(Free) Block Count (High Byte)
		4	System(Free) Block Count (Low Byte)
		5	Reserved
		6	Reserved
		7	Reserved
ECh-FFh	Reserved		

**SMART READ ATTRIBUTE THRESHOLD**

This transfers 512 bytes of drive failure threshold data to the host.

**SMART ENABLE/DISABLE ATTRIBUTE AUTOSAVE**

Enables or disables the attribute value autosave function. This command specifies whether the current attribute values are automatically saved to the drive when it changes the mode. This setting is maintained when the power is turned on and off.

**SMART SAVE ATTRIBUTE VALUE**

Saves any modified attribute values.

**SMART EXECUTE OFF-LINE IMMEDIATE**

This command of Non-data input causes the controller to immediately initiate the set of activities that collect SMART data in a off-line mode and then save data to the Nand flash memory, or execute a selfdiagnostic test routine in either captive or off-line mode.

**SMART ENABL OPERATIONS**

Enables the SMART function. This setting is maintained when the power is turned off and then back on. Once the SMART function is enabled, subsequent SMART ENABLE OPERATIONS commands do not affect any parameters.

**TS8GSSD25S-S**  
**TS16GSSD25S-S/M**  
**TS32GSSD25S-S/M**  
**TS64GSSD25S-S/M**  
**TS128GSSD25S-M**  
**TS192GSSD25S-M**



---

#### **SMART DISABLE OPERATIONS**

Disables the SMART function. Upon receiving the command, the drive disables all SMART operations. This setting is maintained when the power is turned off and then back on.

Once this command has been received, all SMART commands other than SMART ENABLE OPERATIONS are aborted with the Aborted Command error.

This command disables all SMART capabilities including any and all timer and event count functions related exclusively to this feature. After command acceptance, this controller will disable all SMART operations. SMART data is no longer monitored or saved. The state of SMART is preserved across power cycles.

#### **SMART RETURN STATUS**

Reports the drive reliability status.

Values reported when a predicted defect has not been detected:

Cylinder Low register: 4Fh

Cylinder High register: C2h

Values reported when a predicted defect has been detected:

Cylinder Low register: F4h

Cylinder High register: 2Ch

#### **SMART ENABLE/DISABLE AUTOMATIC OFF-LINE**

Enables (when Sector Count register = "F8h") or disables (Sector Count register = "00h") the automatic off-line data collection function. The automatic collection is disabled if a value of "00h" is set in the Sector Count register before a subcommand is issued. If automatic collection is disabled, the drive can still save attribute information during normal operation, such as during the power-on/off sequence or error correction sequence. The automatic collection function is enabled if a value of "F8h" is set in the Sector Count register before the command is issued. Values other than "00h" and "F8h" are vendor-specific.

**TS8GSSD25S-S**  
**TS16GSSD25S-S/M**  
**TS32GSSD25S-S/M**  
**TS64GSSD25S-S/M**  
**TS128GSSD25S-M**  
**TS192GSSD25S-M**

 **Transcend**<sup>®</sup>  
**2.5" Solid State Disk**

---

#### **STANDBY (E2h)**

This command causes the device to set BSY, enter the Sleep mode (which corresponds to the ATA "Standby" Mode), clear BSY and return the interrupt immediately.

#### **STANDBY IMMEDIATE (E0h)**

This command causes the drive to set BSY, enter the Sleep mode (which corresponds to the ATA "Standby" Mode), clear BSY and return the interrupt immediately.

#### **WRITE BUFFER (E8h)**

This command enables the host to write the contents of one 512-byte block of data to the device's buffer.

#### **WRITE DMA (CAh)**

Write data to sectors during Ultra DMA and Multiword DMA transfer. Use the SET FEATURES command to specify the mode value.

#### **WRITE DMA EXT (35h)**

48-bit feature set mandatory command. Write data to sectors during Ultra DMA and Multiword DMA transfer. Use the SET FEATURES command to specify the mode value.

#### **WRITE DMA FUA EXT (3Dh)**

48-bit feature set mandatory command. This command provides the same function as the WRITE DMA EXT command except that regardless of whether volatile and/or non-volatile write caching in the device is enabled or not, the user data shall be written to non-volatile media before command completion is reported.

#### **WRITE FPDMA QUEUED (61h)**

NCQ feature set mandatory 48-bit command. This command causes data to be transferred from the host to the device.

#### **WRITE MULTIPLE (C5h)**

This command is similar to the Write Sectors command. Interrupts are not presented on each sector, but on the transfer of a block which contains the number of sectors defined by Set Multiple command.

**TS8GSSD25S-S**  
**TS16GSSD25S-S/M**  
**TS32GSSD25S-S/M**  
**TS64GSSD25S-S/M**  
**TS128GSSD25S-M**  
**TS192GSSD25S-M**



---

**WRITE MULTIPLE EXT (39h)**

48-bit feature set mandatory command. This command is similar to the Write Sectors command. Interrupts are not presented on each sector, but on the transfer of a block which contains the number of sectors defined by Set Multiple command.

**WRITE MULTIPLE FUA EXT (CEh)**

48-bit feature set mandatory command. This command provides the same functionality as the WRITE MULTIPLE EXT command except that regardless of whether volatile and/or non-volatile write caching in the device is enabled or not, the user data shall be written to non-volatile media before command completion is reported.

**WRITE SECTOR(S) (30h/31h)**

Write data to a specified number of sectors (1 to 256, as specified with the Sector Count register) from the specified address. Specify "00h" to write 256 sectors.

**WRITE SECTOR(S) EXT (34h)**

48-bit feature set mandatory command. Write data to a specified number of sectors (1 to 65536, as specified with the Sector Count register) from the specified address. Specify "00h" to write 65536 sectors.

**TS8GSSD25S-S**  
**TS16GSSD25S-S/M**  
**TS32GSSD25S-S/M**  
**TS64GSSD25S-S/M**  
**TS128GSSD25S-M**  
**TS192GSSD25S-M**



**Ordering Information**

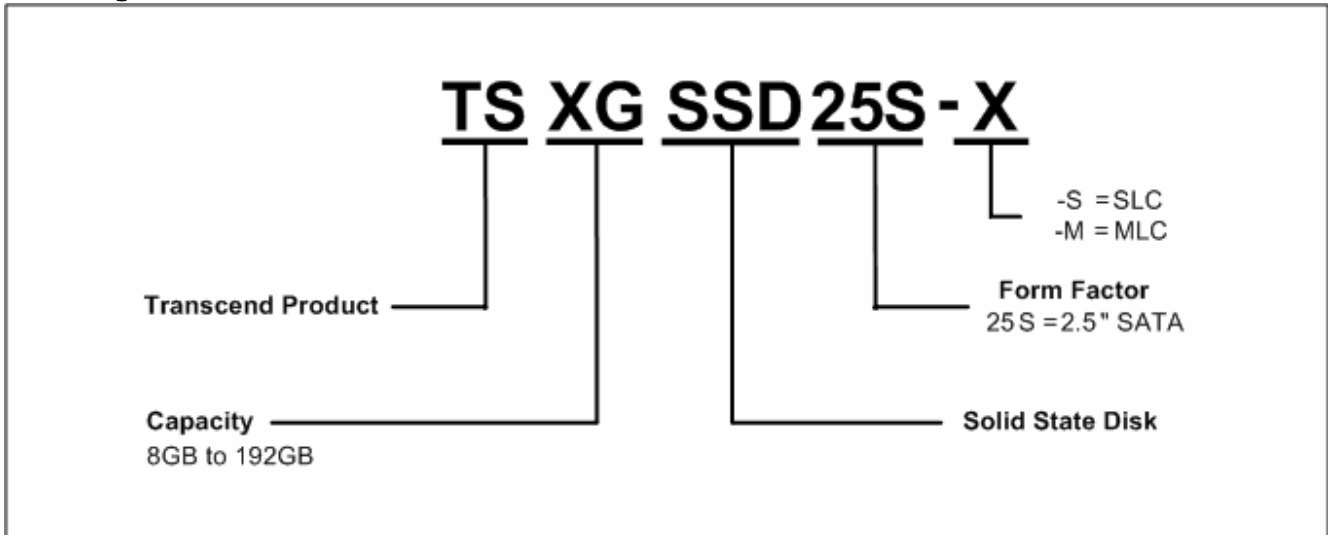

The above technical information is based on industry standard data and has been tested to be reliable. However, Transcend makes no warranty, either expressed or implied, as to its accuracy and assumes no liability in connection with the use of this product. Transcend reserves the right to make changes to the specifications at any time without prior notice.



**TAIWAN**

No.70, XingZhong Rd., NeiHu Dist., Taipei, Taiwan, R.O.C  
 TEL +886-2-2792-8000  
 Fax +886-2-2793-2222  
 E-mail: sales@transcend.com.tw  
[www.transcend.com.tw](http://www.transcend.com.tw)

**USA**

**Los Angeles:**

E-mail: sales@transcendusa.com

**Maryland:**

E-mail: sales\_md@transcendusa.com

[www.transcendusa.com](http://www.transcendusa.com)

**CHINA**

E-mail: sales@transcendchina.com

[www.transcendchina.com](http://www.transcendchina.com)

**GERMANY**

E-mail: vertrieb@transcend.de

[www.transcend.de](http://www.transcend.de)

**HONG KONG**

E-mail: sales@transcend.com.hk

[www.transcendchina.com](http://www.transcendchina.com)

**JAPAN**

E-mail: sales@transcend.co.jp

[www.transcend.jp](http://www.transcend.jp)

**THE NETHERLANDS**

E-mail: sales@transcend.nl

[www.transcend.nl](http://www.transcend.nl)

**United Kingdom**

E-mail: sales@transcend-uk.com

[www.transcend-uk.com](http://www.transcend-uk.com)

**KOREA**

E-mail: sales@transcend.kr

[www.transcend.co.kr](http://www.transcend.co.kr)